

ENCLOSURE RANGE

NOORSA GOSTAR NOVIN

info@noorsa.com

Tel : 00982188211030



TECHNICAL INFORMATION

please always state the ordering number when ordering

F 2

Assembly of Enclosures

Cable glands

The maximum number of cable gland that can be fitted is indicated on the data sheets of each enclosure. This is meant as guide values and applies to cable glands without contern uts • dimensioned to DIN EN 50 262. in case of other glands • e.g. with contern uts or for armoured cable • and in case of mixe assemblies of components • a specific drilling plan is required.

Please specify the type of gland you need. The drill holes on the enclosure side must be located within the permitted mounting area.

This area is limited by the following measurements:

- The drill diameter must be located within the flat inner wall. as an aid to projection • measurement A from the drill hold centre to the inner reference line can be used.

Distance between holes for cable gland

M	PG	Distance	M	PG	Distance	M	PG	Distance	M	PG	Distance
12	7	20mm	12+16	7+9	21mm	16+20	9+11	24mm	20+20	11+13.5	27mm
16	9	22mm	12+20	7+11	23mm	16+20	9+13.5	25mm	20+25	11+16	29mm
20	11	26mm	12+20	7+13.5	24mm	16+25	9+16	27mm	20+32	11+21	34mm
20	13.5	27mm	12+25	7+16	26mm	16+32	9+21	32mm	20+40	11+29	40mm
25	16	32mm	12+32	7+21	31mm	16+40	9+29	37mm	20+50	11+36	45mm
32	21	42mm	12+40	7+29	37mm	16+50	9+36	43mm	20+63	11+42	48mm
40	29	53mm	12+50	7+39	42mm	16+63	9+42	46mm	20+63	11+48	51mm
50	36	63mm	12+63	7+42	46mm	16+63	9+48	49mm			
63	42	70mm	12+63	7+48	48mm						
63	48	75mm									
M	PG	Distance	M	PG	Distance	M	PG	Distance	M	PG	Distance
20+25	13.5+16	30mm	25+32	16+21	37mm	32+40	21+29	50mm	40+50	29+36	61mm
20+32	13.5+21	35mm	25+40	16+29	43mm	32+50	21+36	55mm	40+63	29+42	64mm
20+40	13.5+29	41mm	25+50	16+36	48mm	25+63	21+42	58mm	40+63	29+48	67mm
20+50	13.5+36	49mm	25+63	16+42	51mm	25+63	21+48	61mm			
20+63	13.5+42	49mm	25+63	16+48	54mm						
20+63	13.5+48	52mm									
M	PG	Distance	M	PG	Distance						
50+63	36+42	69mm	63+63	42+48	73mm						
50+63	35+48	72mm									

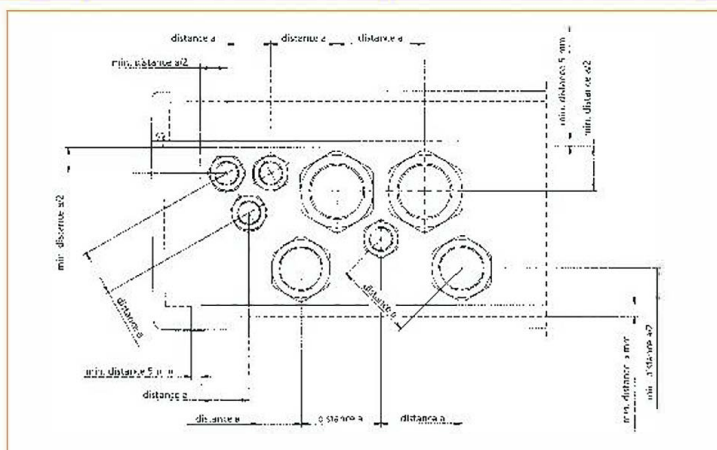

mental as well as plastic glands may be used. Unused entry openings must be sealed with blind plugs ensuring at least IP 54 (gas atmosphere) and IP66 (dust atmosphere) with installation.

EPOXY POWDER COAT and STANDARD PAINT COLOR GUIDE

Something This Important Should Be Standard

Weather extremes, salt water and chemicals corrode conventional paint finishes in no time, leaving critical power connections at risk. That's why only EPP features this tough, durable finish on every coated product at no extra cost. Epoxy powder coat EPP's answer to the harshest conditions, the kind you'll find on oil rigs, at refineries and in pulp and paper mills. It starts with a high-grade powder that's electrostatically applied and oven-baked to form a thick, even layer of protection.

Epoxy Powder Coat Advantages

Lasts longer	Two to three times longer than paint finishes, for increased reliability, reduced downtime and lower replacement costs.
Covers completely	Electrostatic application draws epoxy powder into the smallest crevices, forming a strong bond that guards against peeling and flaking.
Seals tight	Heat-fused powder forms a thick, uniform layer: even, edges • with no bubbles, drips or other surface flaws, for added protection against mechanical damage.
Provides extra protection	On gray iron and malleable iron products, epoxy powder coat is the final step in our exclusive Triple-Coat Finish: applied over zinc plating and dichromate dip, it adds yet another layer of protection.
Won't crack or chip	More flexible than paint, epoxy powder coat expands and contracts with temperature extremes without cracking or chipping.
Safeguards the environment	Airborne overspray particles are essentially nonexistent.

Standard Paint Color Guide

Standard Metallic Color Guide	Product Category	Description Acrylic Enamel#	P.P.G. Industrial	COLOR
	01	Painted Aluminum	RAL7001	Gray
	04	Alufonn	RAL7038	Light Gray
	01	Corrosion-Proof Aluminum	DAR2825H	Bright Blue
	07	P.C. Bard Extrusions 0701, 0702, 0703, 0710, 0711	RAL9005	Black
	07	Profitronic 19Body	RAL7035	White Gray
	07	Profitronic 19Trim	RAL7030	Stone Gray
	88	8850 Support Arms	RAL7035	Light Gray
	49	49, 51, 61, Suspension Components	RAL7043	Dark Gray
	13	Small Machine Control Enclosures 1300 Base	RAL7038	Light Gray
	13	Small Machine Control Enclosures 1300 Bezels	RAL7043	Dark Gray
	SI2000	Thin Profile Machine Control Enclosures	RAL7035	Whit Gray
	54	Large Machine Control Enclosures 5400	DAR5400 SC	Gold Smoke Gray









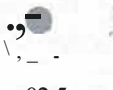

STANDARD NON-METALLIC COLOR GUIDE

Product Category	Description	RAL Color
02	Fiberglass	7000
06	Fiberglass Safety	9011
PK	Polyamide	7001
03, 33, LM	Polycarbonate	7035
09, ET	ABS	7035
21	ABS Cabinets	7035
21	GFK Cabinets	7032
21	Compression-Molded Fiberglass Cabinets	7038
14	Fiberglass Modular Flange	7032
17	Polycarbonate Modular Flange	7032
08	Polyamide Cable Grips	7035
29	Mobil Control Housings	1021

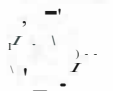

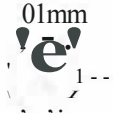
INGRESS PROTECTION

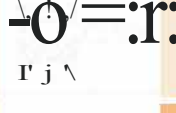
The first digit of the number designates protection from solid objects and the second digit designates protection from moisture. The levels for the first digit vary from 1 through 6 and the second digit 1 through 8 where a larger number means increased protection. The table below summarizes the various IP designations. As you can see, the greatest level of protection is IP68, which is for continuously submerged enclosures.

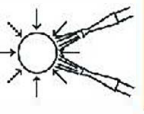
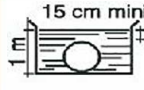
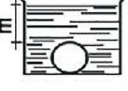
1st figure: Protection against solid bodies			2nd figure: Protection against liquids		
IP	Test		IP	Test	
0		no protection	0		no protection
1	050mm 	protected against solid bodies of 50 mm and greater (e.g. accidental contact with the hand)	1		protected against vertically falling drops of water (condensation)
2	012.5mm 	protected against solid bodies of 12.5 mm and greater (e.g. finger)	2		protected against drops of water falling up to 15° from the vertical
3	02.5mm 	protected against solid bodies of 2.5 mm and greater (e.g. tools, wires)	3		protected against drops of water falling up to 60° from the vertical
4	01mm 	protected against solid bodies larger than 1 mm (e.g. tools and finewires)	4		protected against splashing water from all directions
5		protected against solid dust (no harmful deposit)	5		protected against jets of water from all directions
6		completely protected against dust	6		protected against powerful jets of water from all direction
			7		protected against the effects of temporary immersion in water
			8		protected against the continuous effects of immersion in water having regard to specific conditions

F4

IPxx degree of protection of enclosures of electrical equipment in accordance with standards IEC 60529 and EN 60529

CABLE GRIP INSTALLATION INFORMATION

PG cable glands are in the process of being phased out. These will be replaced with metric type glands. EPP's PG cable grips employ a special thread not generally available in America, therefore we are standardizing with metric.

Accordingly, EPP has a limited stock of taps for sale to customers wishing to drill, tap and install EPP's PG type cable grips at their own facilities. We do not offer metric taps, however they can be purchased through your local hardware supplier.

Listed below is the necessary information for drilling and tapping holes for EPP's PG or metric cable grips and the appropriate tap part number. Thick wall applications require that you tap holes for cable glands. Thin wall applications may be drilled through with a nut.

CROSS REFERENCE CHART

Metric Cable Grip Size	Tap Size	Metric Tapped Hole Size	Inch Tapped Hole Size	Closest American Drill Size	Metric Through Hole Size	Inch Through-Hole
M12	M12x1.5	10.5mm	0.413	z(.413)	12.2mm	0.480
M16	M16x1.5	14.5mm	0.571	37/64"(.578)	16.2mm	0.638
M20	M20x1.5	18.5mm	0.728	47/64"(.734)	20.2mm	0.795
M25	M25x1.5	23.5mm	0.925	59/64"(.922)	25.2mm	0.992
M32	M32x1.5	30.5mm	1.2	-	32.2mm	1.268
M40	M40x1.5	38.5mm	1.516	-	40.2mm	1.583

If you are going to use a polyamide grip with a nut and not going to tap the hole, you will need to drill a larger hole to push the grip through. Use the chart below for the correct size hole.

DRILL HOLE AND TAP INFORMATION

Cable Grip Size	Metric Tapped Hole Size	Inch Tapped Hole Size	Closest American Drill Size	Metric Through-Hole	Inch Through-Hole
PG 7	11.5 mm	0.453	29/64"(.453)	12.3mm	0.484
PG 9	14 mm	0.551	35/64"(.547)	15.1mm	0.594
PG 11	17.25 mm	0.679	46/63"(.672)	19.6mm	0.772
PG13.5	19 mm	0.748	3/4"(.750)	20.2mm	0.795
PG 16	21.25 mm	0.837	53/64"(.828)	22.3mm	0.878
PG 21	27 mm	1.063	1 1/16"(1.063)	28.2mm	1.11
PG 29	35.5 mm	1.791	1 25/64"(1.391)	36.9mm	1.453
PG 36	45.5 mm	1.079	1 51/64"(1.797)	48.8mm	1.921
PG 42	52.8 mm	2.079	2 5/64"(2.078)	-	-
PG 48	58 mm	2.283	2 9/32"(2.281)	-	-

CABLE GRIP SELECTION GUIDE

Wire Size		Metric Size	PG Size	Metric Size
mm	Inches			
3-6.5	.12-.26	M12	PG7	-
4-8	.18-.32	M16	PG9	3/8" NPT
6-10	.24-.39	M16	PG11	-
6-12	.24-.47	M20	-	-
7-12	.28-.47	-	PG13.5	-
10-14	.39-.55	M20	PG16	1/2" NPT
13-18	.51-.71	-	PG21	-
14-18	.55-.71	M25	-	3/4" NPT
20-25	.79-.98	M32	PG29	-
24-32	.95-1.26	M40	Pg36	1" NPT
32-38	1.26-1.50	M50	Pg42	-
37-44	1.46-1.73	M63	PG48	-

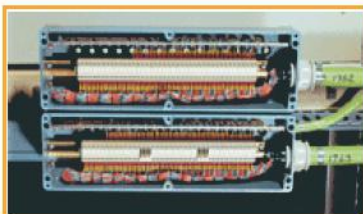

POLYCARBONATE SPECIFICATIONS

Features excellent strength, stiffness and impact resistance, very good thermal stability, tough yet flexible down to -150° F, excellent dimensional accuracy and stability, weather resistance, excellent light transmission (up to 89% with translucent grades), good electrical insulating properties. High gloss finish.

Mechanical fastening is a good technique for attaching materials and components to polycarbonate.

It is relatively quick and provides high assembly strength. In addition, mechanical fastening does not subject the plastic to chemical changes, accordingly, losses in the properties of the polycarbonate are minimized.

Screws are one form of mechanical fastening used to minimize induced assembly stresses in polycarbonate use.

Thread cutting, rather than thread forming screws are recommended. A thread forming screw merely displaces material, setting-up areas of high stress.

THREAD CUTTING screws remove material and do not cause excessive stress when used properly.

POLYCARBONATE IS NOT TOLERANT OF OIL IN GENERAL AND HIGH SULFIDE OILS, IN PARTICULAR.

IF OIL IS CONTINUOUSLY PRESENT, WE DO NOT RECOMMEND POLYCARBONATE.

Physical Properties	Approx. Value	Unit of Measurement	Standard
Tensile stress, break	70 - 69	Mpa	ISO527 - ASTM D 638
Tensile strain, break	110 - 130	%	ISO527 - ASTM D638
Tensile stress, yield	63 - 62	Mpa	ISO527 - ASTM D638
Tensile strain, yield	6 - 7	%	ISO527 - ASTM D638
Tensile modulus	2350	Mpa	ISO527
Flexural stress, yield	90 - 97	Mpa	ISO178 - ASTM D 790
Flexural modulus	2300 - 2340	Mpa	ISO178 - ASTM D790
Izod impac, unnotched			
+23°C	No failure	KJ/m ²	ISO 180/1U
-30°C	No failure	KJ/m ²	ISO 180/1U
+23°C	3204	JM	ASTM D 4812
Izod impact, notched			
+23°C	25	KJ/m ²	ISO 180/1A
-30°C	10		ISO 180/1A
+23°C	801	JM	ASTM D 256
Charpy impact, notched			
+23°C	No failure	KJ/m ²	ISO179/1eU
-30°C	No failure	KJ/m ²	ISO179/1eU
Charpy impact, notched +23°C	35	KJ/m ²	ISO179/2C
Taber abrasion, CS-17, 1kg	10	Mg/1000cy	ASTM 1044
Ball indentation 125°	Passes		IEC 60695-10-2
Thermal conductivity	0.2 - 0.27	W/m—°C	ISO8302- ASTM C 177
Specific heat	1.26	J/g.°C	ASTM C 351
Vicat Softening Temperature			
Method b	141	°C	ISO 306/ASTM D 1525
Method a	153		
Long term service temperature	115 - 135	°C	
Heat deflection temperature			
Method A	135	°C	ISO75
Method B	140		ISO75
Flame resistance test	V-2		UL94
Shrinkage	0.5-0.7	%	
Dielectric strength, in air,			
3.2mm	15	KV/mm	ASTM D 149
1.0mm	35		IEC 60243-1
in oil, 0.8mm	27		IEC 60243-1
in oil, 1.6mm	17		IEC 60243-1
in oil, 3.2mm			IEC 60243-1
Surface resistivity	>10 ¹⁵	Ohms	IEC 60093
Volume resistivity	10 ¹⁵	Ohm-cm	IEC 60093
Permittivity	2.7		
50Hz	2.7		IEC 60250
1MHz			IEC 60250
Water absorption			
23°C, 50% RH	0.15	%	ISO62
23°C, storage in H ₂ O	0.35		ISO62



Fitting of Terminals

With the enclosures there is indicated an assembly length, by which the quantity of applicable terminals can be calculated. This is independent of the side of cable entries.

The enclosure are stated with the attachment length.

The number may need to be reduced, depending on the actual current flowing through an earth connection.

Example 1:

Enclosure with 24 10 mm² terminals:

The max. number of terminals for the equipment (physical dimensions) results from the maximum equipment length of 252 mm

The width of the terminal blocks for 10 mm² is 10.2 mm. This allows the equipment with 24 terminals (252 : 10.2 = 24 terminals + rest)

Equipment according to heat computation

1) Full use of all 10 mm² conductors with 16 A:

max. equipment is possible, as the values are within the green fields

2) Full use of the conductors with 50 A:

9 conductors are permissible = 4 terminals (10 mm²)

Example 2:

Mixed equipment: Enclosure with

8 x 2.5 mm² terminals with 10 A

3 x 4 mm² terminals with 20A

3 x 16 mm² terminals with 50A

Cross section/mm ²	Current/amps	Number/utilisation
2,5	10	8 / (of 31)= 25 %
4	20A	3 / (of 12) = 25 %
16	50	3 / (of 9) = 33 %

Sum = 83% < 100 %

this means, that on technical heat grounds this equipment is permitted.

Where the rated current is within the green fields, any number of terminals can be used over the equipment lengths. In the white area, the maximum equipment is stated, taking the heat generation into account. If this is not fully used, the addition of terminals from the green area is permitted up to the equipment limit. This enclosure may not be used when the application applies to one of the red fields. A larger enclosure must be selected, the application of which will be in the green or white area.

Each terminal point may only be assigned one conductor. If cross connections are required, insert or screw-type jumpers can be used. To avoid the reduction of air gaps or creepage paths, partition plates must be used between neighbouring jumpers. Limitations for these accessories with regard to amperage and voltage also have to be taken into account. This applies in particular when using jumpers at every other terminal (e.g. terminal 1+3+5+7+9 bridged). In such cases, refer to the manufacturer information given in the relevant documentation.

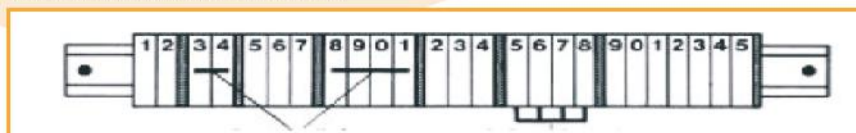

Drawings & Design

DESIGNING WITH EPP

EPP offers the engineer faced with packaging requirements, an enormous advantage in finding a solution. Electronic products need enclosures. Our ability to deliver off-the-shelf enclosures makes EPP one of the most important partners an engineer could ask for when bringing product to market. We offer both electrical and electronic enclosures and have one of the widest ranges of standard off-the-shelf enclosures in the industry.

EPP also offers years of expertise in machining and other value added services, as well as technical support from

an experienced sales force. EPP guarantees all secondary services and machining 100%, thereby eliminating scrap and additional costs.

The benefits of designing with EPP enclosures are: cost savings, elimination of custom tool/molding expense, a large off-the-shelf inventory, no scrap, machining expertise and over 25 years experience in enclosure manufacturing.

Take advantage of our experience and reduce your frustrations from dealing with multiple vendors. EPP can offer you a turnkey solution that is 100% guaranteed.

DRAWINGS

EPP has included various product drawings in this catalog that may not contain all the necessary dimensional information

required for engineering. These are catalog drawings and not always to scale. However, the dimensional and construction

information serves as a good starting point for choosing the right enclosure for your application.

CUSTOM DESIGNS

EPP not only supplies empty standard enclosures, but can also provide and deliver custom designs. We have skilled

technical support personnel in-house that will work with your engineering staff on a custom enclosure design for your

next product. By means of direct communications with you, the customer, we can create an individual solution to fit your precise requirements.

SPECIAL MATERIALS

EPP can injection-mold most plastic enclosures in special colors and/or special materials. Minimum quantities for special injection runs range from 500 to 1,000 units depending on the enclosure. For special colors, please send us a sample of the color you would like to match. EPP cannot guarantee an exact color match. If you need

a special material for improved flame retardancy, impact resistance, chemical resistance, etc., let us know specifically what specifications you need to meet. We will suggest a material suitable for use in our molds that meets your requirements.



Available as component

to personalize A large variety of size Customized to use's own specification

- Design suits your needs
- Speedy design and manufacture
- Delivered ready to install

Technical Specifications

Enclosure

- Material: Aluminum ALSi12
- Orange (Two Coat) Electrostatic Powder Coated RAL 1026 (Other colors available on request)
- Ingress Protection EBM IP66 with Silicone Gasket (Neoprene Optional)
- Stainless Steel Unlosable Screws

Rated Voltages

- Dependent on the components fitted in the box
- (e.g.: with Terminal Block : Max 500V)

Cable Entries

- ISO Entries and Threads (PG Optional)
- Polyamide Cable Glands for Non-Armored Cable
- Nickel Chromed Brass Cable Glands for Non-Armored Cable
- EPP Industrial Cable Glands, A2F and EIW Types
- See cable Galands Range

Products Characteristics

- Unlosable Stainless Steel Screws (Material Standard ASTM A193, Threads: DIN13)
- Silicone Gasket (Specification of Chemical Resistance and Resistance of Substances against Solvents ,Oil and Fats are made available.)
- Stainless Steel External Earth (On request)
- Rail DIN (On request)
- Specification Lable
- Serrated Washer
- Ingress Protection IP66

Fixing

EBM Fixing on the rear of the box by M6x30 screws (not supplied), accessible from the front when cover is removed.

Type	Dimensions A x B x C	Maximum number of terminals Size (in mm ²) in Max (mA)								Order No.
		2.5 mm ² 8.5A	4 mm ² 11A	6 mm ² 21A	10 mm ² 27.5A	16/25 mm ² 40/62A	35 mm ² 72A	70 mm ² 100A	120 mm ² 120A	
EBM 40	120x120x86	15	12	9	7	6	4	-	-	1055620101
EBM 50	150x150x120	19	16	12	10	8	-	-	-	1055620102
EBM 55	150x150x150	19	16	12	10	8	-	-	-	1055620103
EBM 60	230x120x90	37	30	24	19	15	10	-	-	1055620104
EBM 70	200x200x120	43	36	27	21	18	14	-	-	1055620105
EBM 75	200x200x150	43	36	27	21	18	14	-	-	1055620106
EBM 80	200x250x120	54	44	34	13	11	9	9	-	1055620107
EBM 85	200x250x150	56	46	34	24	11	9	9	-	1055620108
EBM 90	250x250x120	104	88	86	52	22	18	-	-	1055620109
EBM 95	250x250x150	104	88	86	52	22	18	11	-	1055620110
EBM 100	200x300x120	86	72	56	44	18	14	-	-	1055620111
EBM 105	200x300x150	86	72	56	44	18	14	-	-	1055620112
EBM 110	250x350x120	120	95	54	30	25	18	4	4	1055620113

Dimensions are in Millimetres

F
10

Dimensions

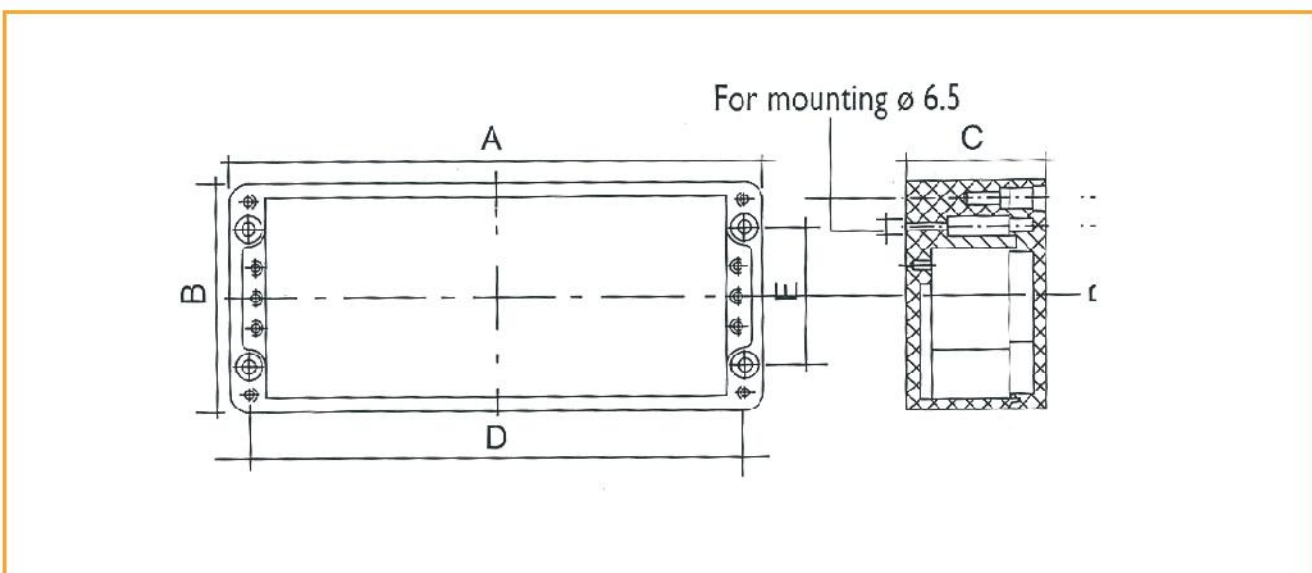

- Accessories available**
- Armored Cable Gland** See page: E16-E22
- Unarmored Cable Gland** See page: E10-E15
- Brass Stopping Plug** See page: E29-E30
- Brass Locknut** See page: E26-E27

Unpainted Version JunctionBox



Available as component

to personalize A large variety of size Customized to use's own specification

- Design suits your needs
- Speedy design and manufacture
- Delivered ready to install

Technical Specifications

Enclosure

- Material: Aluminum ALSi12
- Orange (Two Coat) Electrostatic Powder Coated RAL 1028 (Other colors available on request)
- Ingress Protection EBM IP66 with Silicone Gasket (Neoprene Optional)
- Stainless Steel Unlosable Screws

Rated Voltages

- Dependent on the components fitted in the box
- (e.g.: with Terminal Block : Max 500V)

Cable Entries

- ISO Entries and Threads (PG Optional)
- Polyamide Cable Glands for Non-Armored Cable
- NiKel Chromed Brass Cable Glands for Non-Armored Cable
- EPP Industrial Cable Glands, A2F and EIW Types
- See cable Galands Range

Products Characteristics

- Unlosable Stainless Steel Screws (Material Standard ASTM A193, Threads: DIN13)
- Silicone Gasket (Specification of Chemical Resistance and Resistance of Substances against Solvents ,Oil and Fats are made available.)
- Stainless Steel External Earth (On request)
- Rail DIN (On request)
- Specification Lable
- Serrated Washer
- Ingress Protection IP66

Fixing

EBM Fixing on the rear of the box by M6x30 screws (not supplied), accessible from the front when cover is removed.

Type	Dimensions A x B x C	Maximum number of terminals Size (in mm ²) in Max (mA)								Order No.
		2.5 mm ² 8.5A	4 mm ² 11A	6 mm ² 21A	10 mm ² 27.5A	16/25 mm ² 40/62A	35 mm ² 72A	70 mm ² 100A	120 mm ² 120A	
UVB 40	120x120x86	15	12	9	7	6	4	-	-	1055620201
UVB 50	150x150x120	19	16	12	10	8	-	-	-	1055620202
UVB 55	150x150x150	19	16	12	10	8	-	-	-	1055620203
UVB 60	230x120x90	37	30	24	19	15	10	-	-	1055620204
UVB 70	200x200x120	43	36	27	21	18	14	-	-	1055620205
UVB 75	200x200x150	43	36	27	21	18	14	-	-	1055620206
UVB 80	200x250x120	54	44	34	13	11	9	9	-	1055620207
UVB 85	200x250x150	56	46	34	24	11	9	9	-	1055620208
UVB 90	250x250x120	104	88	86	52	22	18	-	-	1055620209
UVB 95	250x250x150	104	88	86	52	22	18	11	-	1055620210
UVB 100	200x300x120	86	72	56	44	18	14	-	-	1055620211
UVB 105	200x300x150	86	72	56	44	18	14	-	-	1055620212
UVB 110	250x350x120	120	95	54	30	25	18	4	4	1055620213

Dimensions are in Millimetres

Dimensions

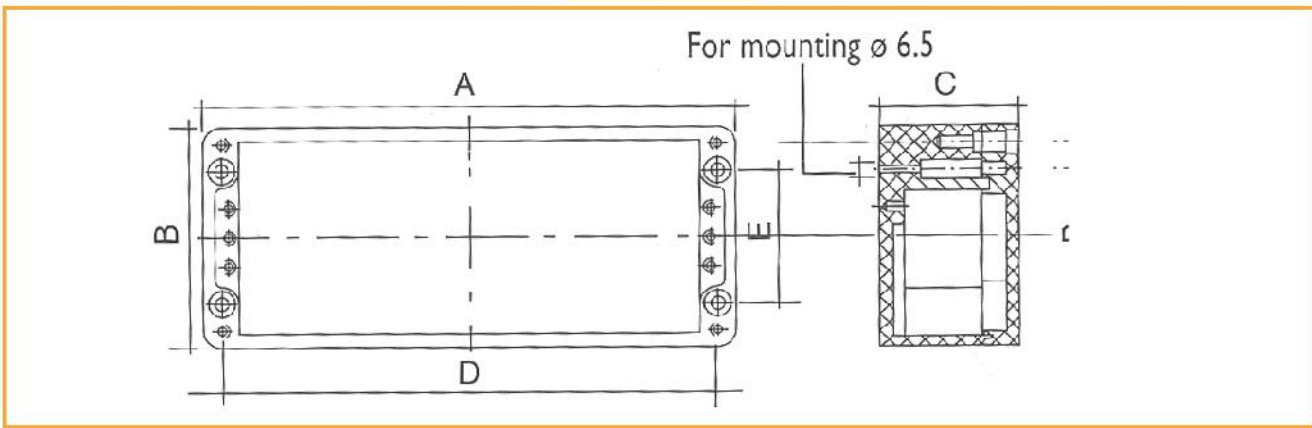

EPP's watertight diecast aluminum enclosure is available in an unpainted version.

For the engineers who want to do machining in-house or wish for us to do machining or other secondary service operations, the unpainted version is the best option.

The features are the same as the painted version.

Each aluminum enclosure consists of a die-cast base and lid, captive stainless steel lid screws, copper ground screws, and a standard Silicon gasket. If a neoprene gasket is required, it must be ordered separately at additional cost and will replace the standard neoprene gasket.

- Accessories available**
- Armored Cable Gland** See page: E16-E22
- Unarmored Cable Gland** See page: E10-E15
- Brass Stopping Plug** See page: E29-E30
- Brass Locknut** See page: E26-E27

Control Box

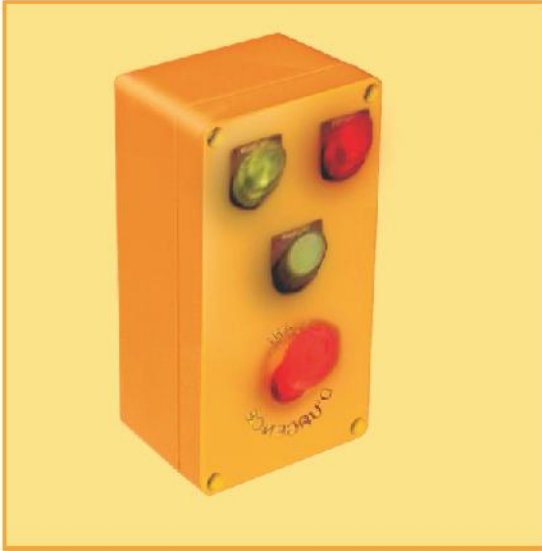

Available as component

to personalize A large variety of size Customized to use's own specification

- Design suits your needs
- Speedy design and manufacture
- Delivered ready to install

Technical Specifications

Enclosure

- Material: Aluminum ALSi12
- Orange (Two Coat) Electrostatic Powder Coated RAL 1028 (Other colors available on request)
- Ingress Protection EBM IP66 with Silicone Gasket (Neoprene Optional)
- Stainless Steel Unlosable Screws

Rated Voltages

- Dependent on the components fitted in the box
- (e.g.: with Terminal Block : Max 500V)

Cable Entries

- ISO Entries and Threads (PG Optional)
- Polyamide Cable Glands for Non-Armored Cable
- Nielkel Chromed Brass Cable Glands for Non-Armored Cable
- EPP Industrial Cable Glands, A2F and EIW Types
- See cable Galands Range

Products Characteristics

- Unlosable Stainless Steel Screws (Material Standard ASTM A193, Threads: DIN13)
- Silicone Gasket (Specification of Chemical Resistance and Resistance of Substances against Solvents ,Oil and Fats are made available.)
- Stainless Steel External Earth (On request)
- Rail DIN (On request)
- Specification Lable
- Serrated Washer
- Ingress Protection IP66

Fixing

EBM Fixing on the rear of the box by M6x30 screws (not supplied), accessible from the front when cover is removed.

Type	Dimensions A x B x C	Maximum number of terminals Size (in mm ²) in Max (mA)								Order No.
		2.5 mm ² 8.5A	4 mm ² 11A	6 mm ² 21A	10 mm ² 27.5A	16/25 mm ² 40/62A	35 mm ² 72A	70 mm ² 100A	120 mm ² 120A	
CB EBM 40	120x120x86	16	12	9	7	6	4	-	-	1055620301
CB EBM 50	150x150x120	19	16	12	10	8	-	-	-	1055620302
CB EBM 56	150x160x150	19	16	12	10	8	-	-	-	1055620303
CB EBM 60	230x120x90	37	30	24	19	15	10	-	-	1055620304
CB EBM 70	200x200x120	43	36	27	21	18	14	-	-	1055620305
CB EBM 75	200x200x150	43	36	27	21	18	14	-	-	1055620306
CB EBM 80	200x250x120	54	44	34	13	11	9	9	-	1055620307
CB EBM 85	200x250x150	56	46	34	24	11	9	9	-	1055620308
CB EBM 90	250x250x120	104	88	86	52	22	18	-	-	1055620309
CB EBM 96	250x250x150	104	88	86	52	22	18	11	-	1055620310
CB EBM 100	200x300x120	86	72	56	44	18	14	-	-	1055620311
CB EBM 105	200x300x150	86	72	56	44	18	14	-	-	1055620301
CB EBM 110	250x350x120	120	96	54	30	25	18	4	4	1055620312

Dimensions are in Millimetres

F
14

Dimensions

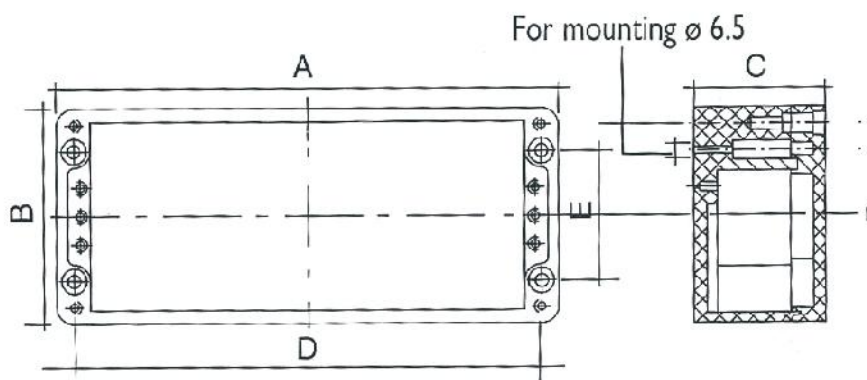

Accessories available

Armored Cable Gland	See page:E16-E22
Unarmored Cable Gland	See page:E10-E15
Brass Stopping Plug	See page:E29-E30
Brass Locknut	See page:E26-E27

EBP

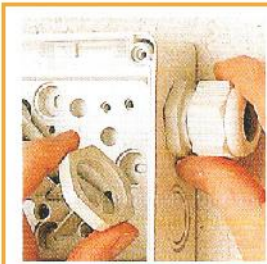
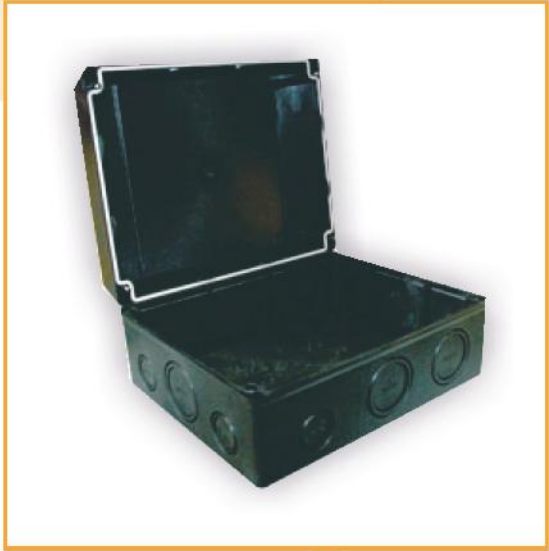

Degree of protection IP 65 by means of threaded cable glands UPG&UM available as accessories.
(See Page: E46 & E49)

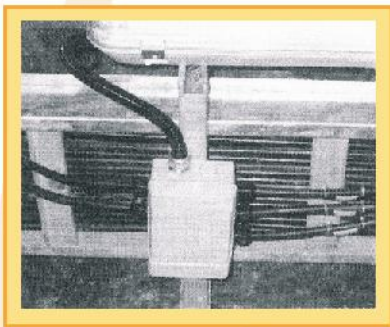

Material: ABS

With plain walls

Degree of protection IP65

With metric knock outs for cable entry

Color: White' Black

EBP-Cable junction boxes:

- Degree of protection IP 65
- Flame retardant, self-extinguishing, Made of high-grade material Reinforced thermoplastics, impact proof;

EBP-Cable junction boxes comply with regulatory restrictions for buildings with requirements regarding the structural fire protection!

halogenfree:

- Low toxicity
- Low fume development

Weather-proof

- UV-resistant
- Rainproof
- Temperature resistant
- Impact proof

Type	Carton Qty	Order No.
EBP 40	40	1055630101
EBP 50	30	1055630102
EBP 60	20	1055630103
EBP 90	10	1055630104



EBP40
139x119x70 mm

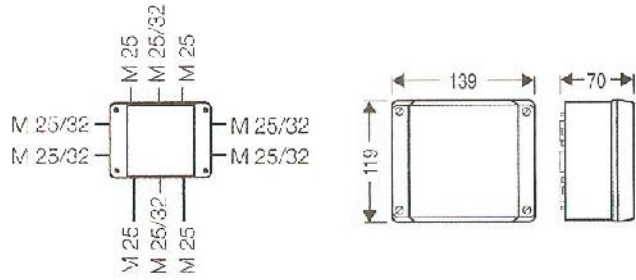

EBP50
167x125x82 mm

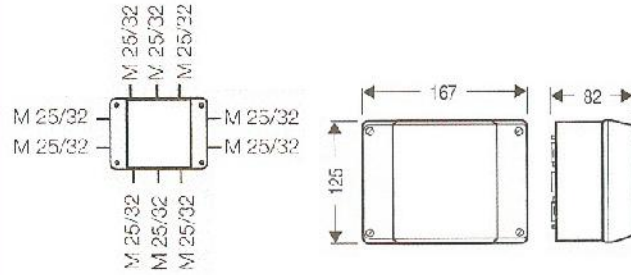

EBP60
200x160x98 mm

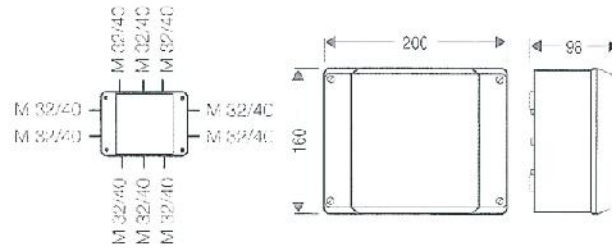

EBP90
310x210x116 mm

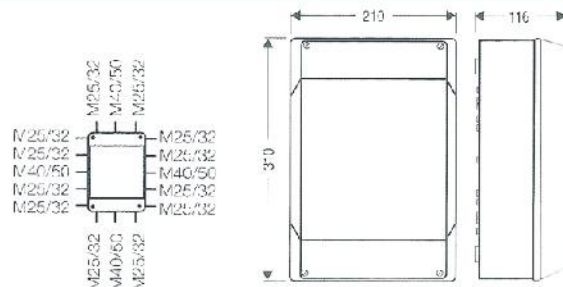

Accessories available

Grommet (SEG Type) See page: F22

Polymer Cable Gland See page: E46&E49

Polymer Stopping Plug See page: E50

Polymer Locknut See page: E51

Thermoplastic Enclosures With Transparent Cover



Material (Body) : ABS, Impact-Proof

Material (Cover) : Polycarbonate, Impact-Proof

With plain walls

Degree of protection: IP65

With metric knock outs for cable entry

color: White + Black

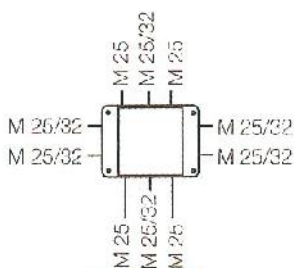

EBTC 40

139x119x70 mm

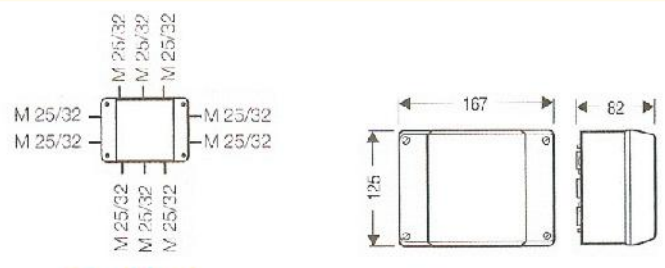

EBTC 50

167x125x82 mm

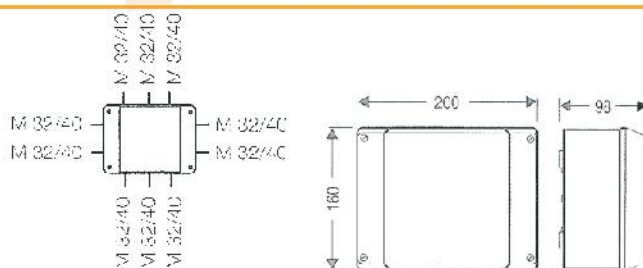

EBTC 60

200x160x98 mm

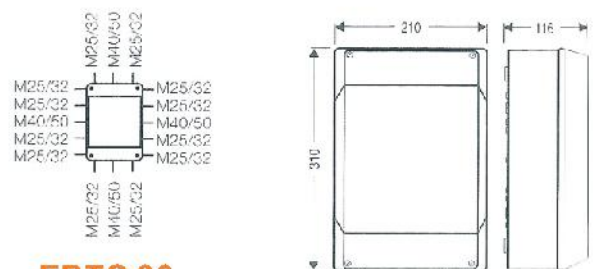

EBTC 90

310x210x116 mm

Accessories available

Grommet (SEG Type)	See page: F22
Polymer Cable Gland	See page: E46&E49
Polymer Stopping Plug	See page: E50
Polymer Locknut	See page: E51

Type	Carton Qty	Order No.
EBTC 40	40	1055630201
EBTC 50	30	1055630202
EBTC 60	20	1055630203
EBTC 90	10	1055630204

DISTRIBUTION BOX

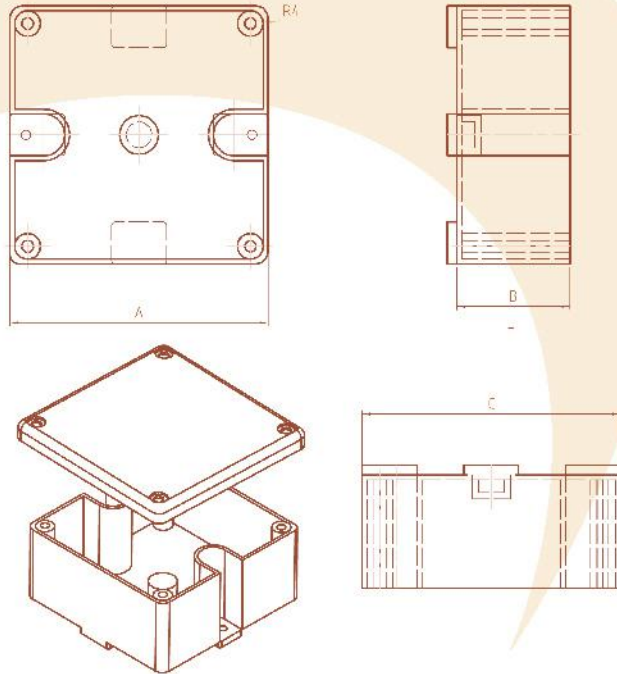

Type	Dimensions			Carton Qty	No. of Screw DIN 7981	Grommet Type	No. of Grommet	Order No.
	A	B	C					
EDB 20	80	35	80	100	4	TCG	4	1055630301
EDB 30	100	39	100	100	4	TCG	4	1055630302
EDB 40	100	45	150	50	4	CHG	4	1055630303
EDB 50	150	56	200	40	4	CHG	4	1055630304

Dimensions are in Millimetres

High Resistance to Chemical and Atmospheric Agents.

Material: Polystyrene, Impact-Proof

Color: White, Black

Application: Home, Hotels, Sleeping Rooms, Restaurants, Etc.

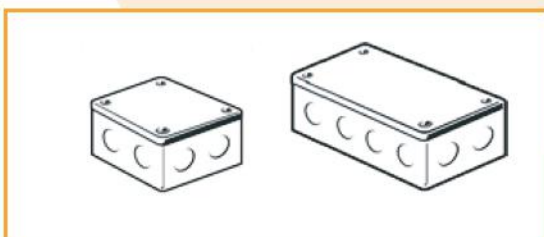

Accessories available	
Grommet (TCG Type)	See page F22
Grommet (CHG Type)	See page F22
Polymer Cable Gland	See page: E46&E49
Polymer Stopping Plug	See page: E50
Polymer Locknut	See page: E51

POLYCARBONATE BOX

EPP accepted Polycarbonate enclosures stand up to the harshest environments to help you protect your devices . They protect against dust , water and corrosion while enhancing the value of your product . EPP Polycarbonate enclosures are available in a wide range of sizes and a selection of materials to meet almost any application.

Tooling is modular , resulting in cost effective customization.
Custom colors, imprints, etc. are possible. EPP Polycarbonate enclosures can be supplied with preinstalled terminal blocks and strain reliefs.

characteristics

- * IP65 (With Silicon Washers)
- * Smooth or Knockout Sidewalls
- * Seamless Integral Seals
- * Matching Black or Transparent Covers
- * Polycarbonate Cover Screws

Quick Access

- * Smooth or Knockout Sidewalls
- * Seamless Integral Seals
- * Quick Release Latches



High Resistance to Chemical and Atmospheric Agents.
with metric knock outs for cable entry

Material (Body) : ABS, Impact-Proof

Material (Cover) : Polycarbonate, Impact-Proof

Color: Black

Application: Home, Hotels, Sleeping Rooms, Restaurants, Etc.

Montage Plate

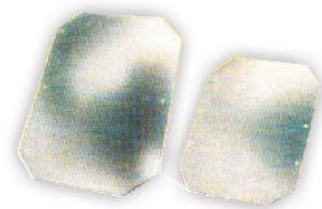

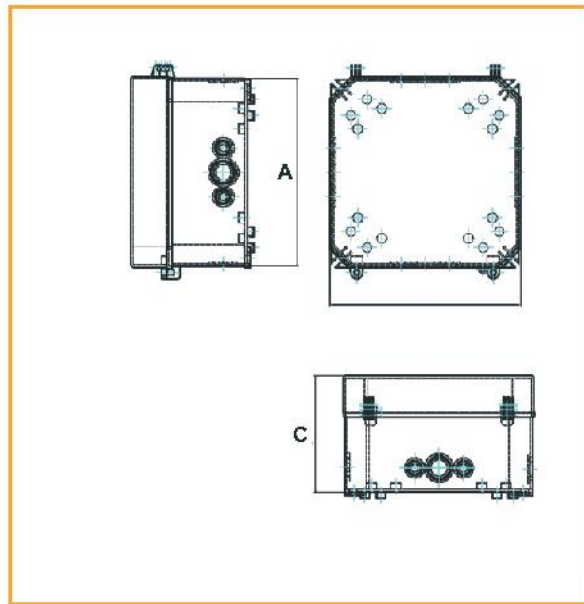
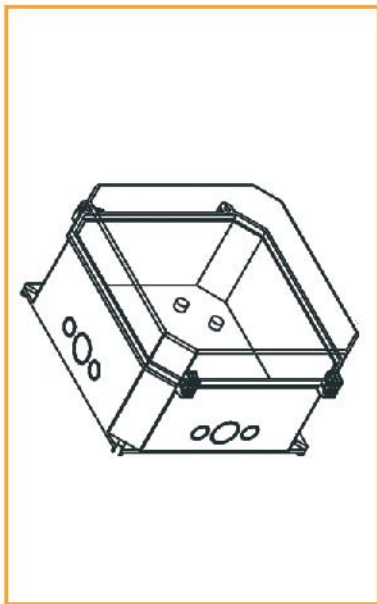

Type	Dimensions			Carton Qty	Order No.
	A	B	C		
EBT 40	200	150	120	12	1055630401
EBT 50	250	150	120	8	1055630402
EBT 60	250	250	120	4	1055630403
EBT 70	300	250	120	4	1055630404
EBT 80	200	150	150	12	1055630405
EBT 90	250	150	150	4	1055630406
EBT 100	250	250	150	8	1055630407
EBT 110	300	250	150	4	1055630408
EBT 120	450	250	150	4	1055630409
EBT 130	450	250	200	4	1055630410

Dimensions are in Millimetres

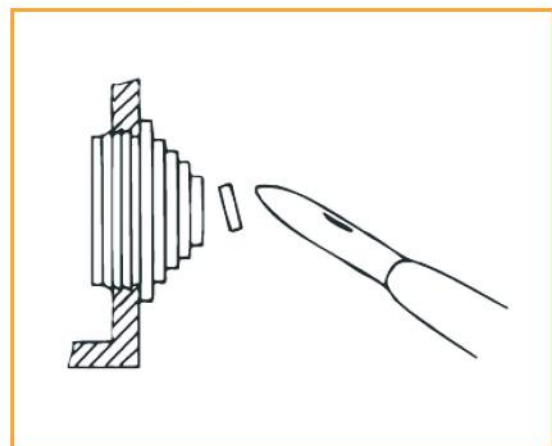

Diameter, Flexible Cut-to-fit Cable Entries Graduated

- Accessories available
- Grommet See page F22
- Polymer Cable Gland See page:E46&E49
- Polymer Stopping Plug See page:E50
- Polymer Locknut See page:E51

MINIATURE BOX (TARA)

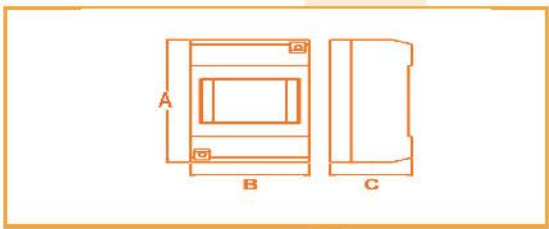
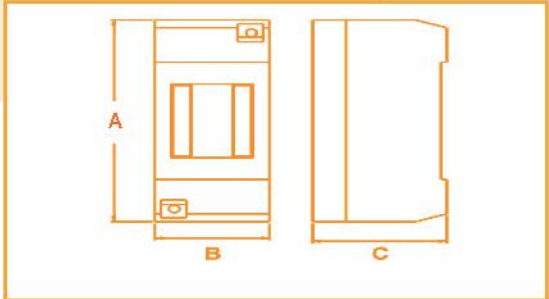

Type	Dimensions			Carton Qty	Order No.
	A	B	C		
1 PHASE	132	61	60	100	1055640101
3 PHASES	132	87	60	100	1055640102

Dimensions are in Millimetres

High Resistance to Chemical and Atmospheric Agents.

Material: ABS, Polystyrene, Impact-Proof

Color: White, Light Gray

Degree of Protection: IP20

Application: Home, Hotels, Sleeping Rooms, Restaurants, Etc.

BLIND TAG

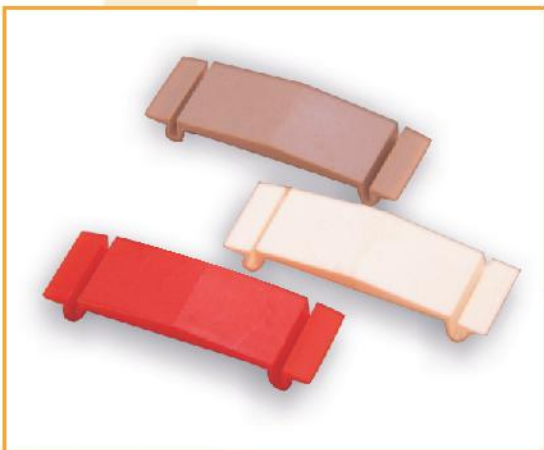

Material: ABS

Color: Various color

A	B	C	D
39	41	2	2

Dimensions are in Millimetres

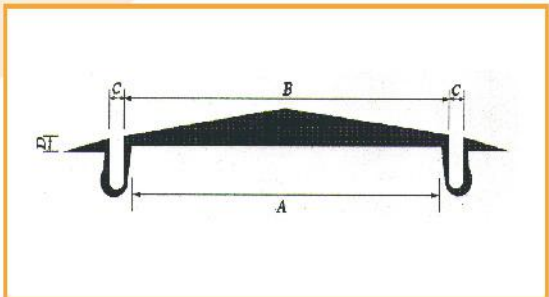

Type	Pack Qty	Order No.
MSP	3000	1055640103

GROMMET

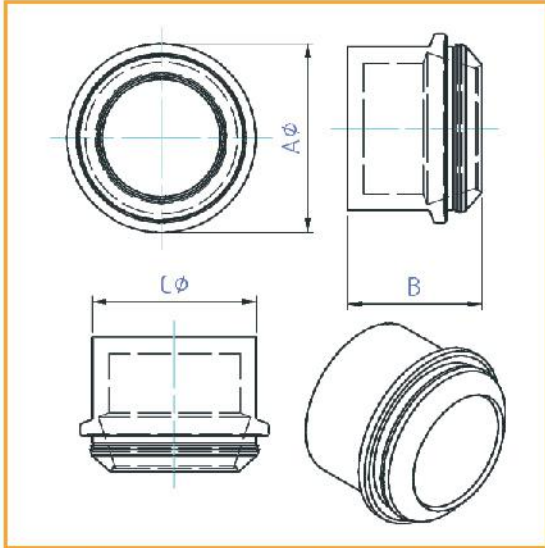

Type	Dimensions			Material	Color	Order No.
	A	B	C			
SEG M32	39	26	32	PVC	L.Gray-White	1055640201
SEG M40	46	26	40	PVC	L.Gray-White	1055640202

Dimensions are in Millimetres

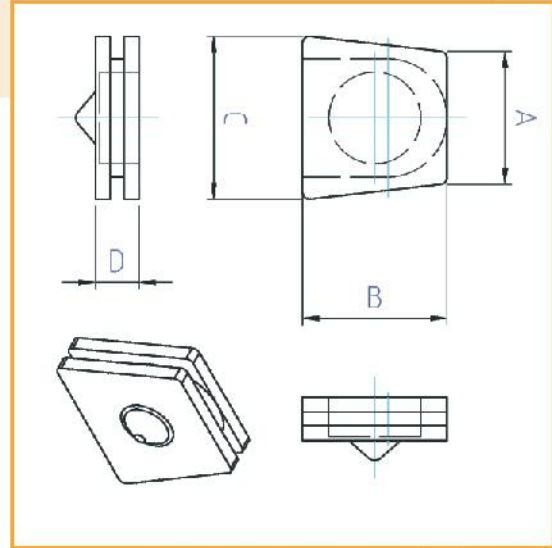

Type	Dimensions				Material	Color	Order No.
	A	B	C	D			
TCG	21	21	24	6.7	PVC	White-Black	1055640204

Dimensions are in Millimetres

Splash-Proof Fittings

Flexible fittings snap into access holes on enclosures. Graduated diameter, cut-to-fit sizing accommodates a wide range of cable diameters. Can also function as a splash-proof plug on knocked-out enclosure access hole.

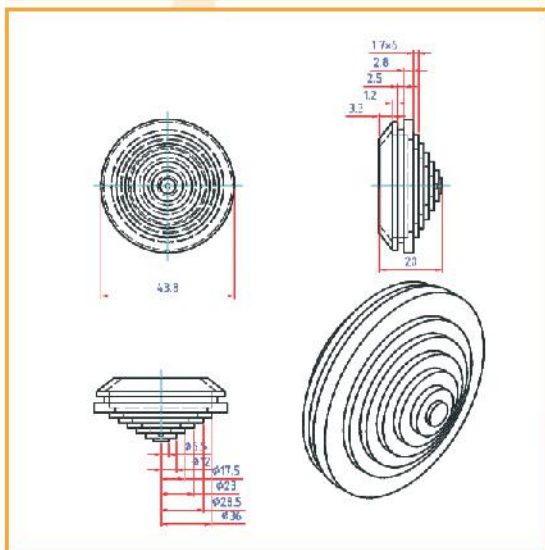

Type	Material	Color	Order No.
SPF	PVC	L.Gray-White	1055640203

Dimensions are in Millimetres

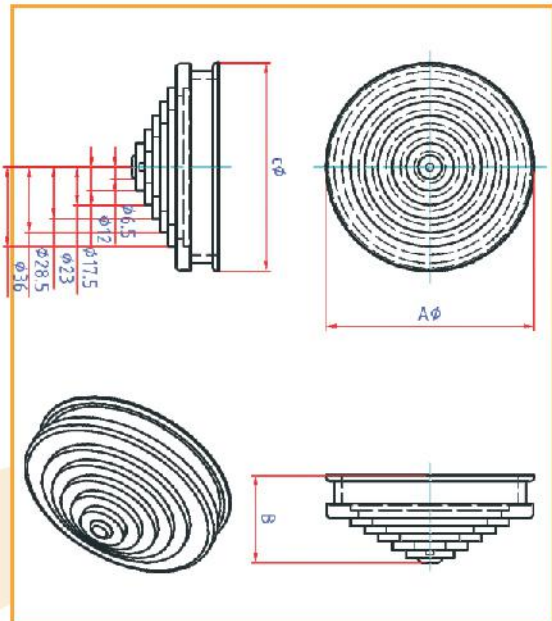

Type	Dimensions			Material	Color	Order No.
	A	B	C			
CHG	33	18	33	PVC	White-Black	1055640205

Dimensions are in Millimetres

END GROMMETS FOR STEEL CONDUIT

Nominal Size	For conduit ø	D1	D2	L1	L2
pg 7	12.5	15.8	10	17	3.5
pg 9	15.2	18.3	12	20	4
pg 11	18.6	21.7	16	22	4
pg 13.5	20.4	20.4	16	23.1	2.5
pg 16	22.5	22.5	18	23.6	2.5
pg 21	28.3	28.3	24	24.9	3
pg 29	37	37	32.5	27.7	3
pg 36	47	47	40	32.5	3.5
pg 42	54	54	46	32.3	4
pg 48	59.3	59.3	50	32.1	4.4

Dimensions are in Millimetres

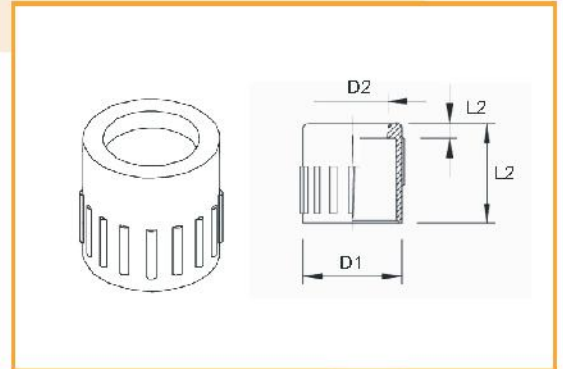

Type	Nominal Size	Color	Pack Qty	Order NO.
EG 7	Pg 7	White	100	1055640401
EG 9	Pg 9	White	100	1055640402
EG 11	Pg 11	White	100	1055640403
EG 13.5	Pg 13.5	White	50	1055640404
EG 16	Pg 16	White	50	1055640405
EG 21	Pg 21	White	50	1055640406
EG 29	Pg 29	White	50	1055640407
EG 36	Pg 36	White	50	1055640408
EG 42	Pg 42	White	25	1055640409
EG 48	Pg 48	White	25	1055640410

Dimensions are in Millimetres

Material: Polyethylene

Color: White and lightgrey (RAL 7035)

Cable protection grommet to be fitted to steel conduit to DIN 49020 and medium-and heavy - duty conduits of insulating material to DIN 49016

GROMMETS FOR STEEL CONDUIT

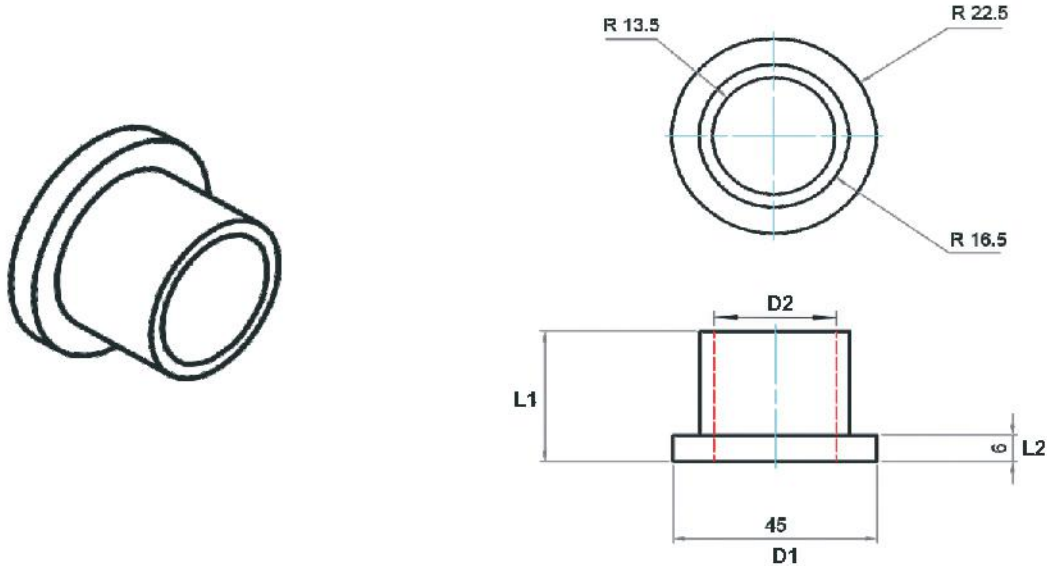

Size	Dimensions				Pack Qty	Order No.
	L1	D2	D1	L2		
3/4	18	22			100	1055640301
1	20	27			100	1055640302
1(1/4)	33	38			100	1055640303
1(1/2)	39	43			50	1055640304
2	51	56			50	1055640305
2(1/2)	69	74			50	1055640306
3	80	84			25	1055640307
4	108	112			25	1055640308

Dimensions are in Millimetres

Material: PVC

Color: Black

Cable protection grommet to be fitted to steel conduit to DIN 49020 and medium- and heavy-duty conduits of insulating material to DIN 49016